

# Filtrato Softeners

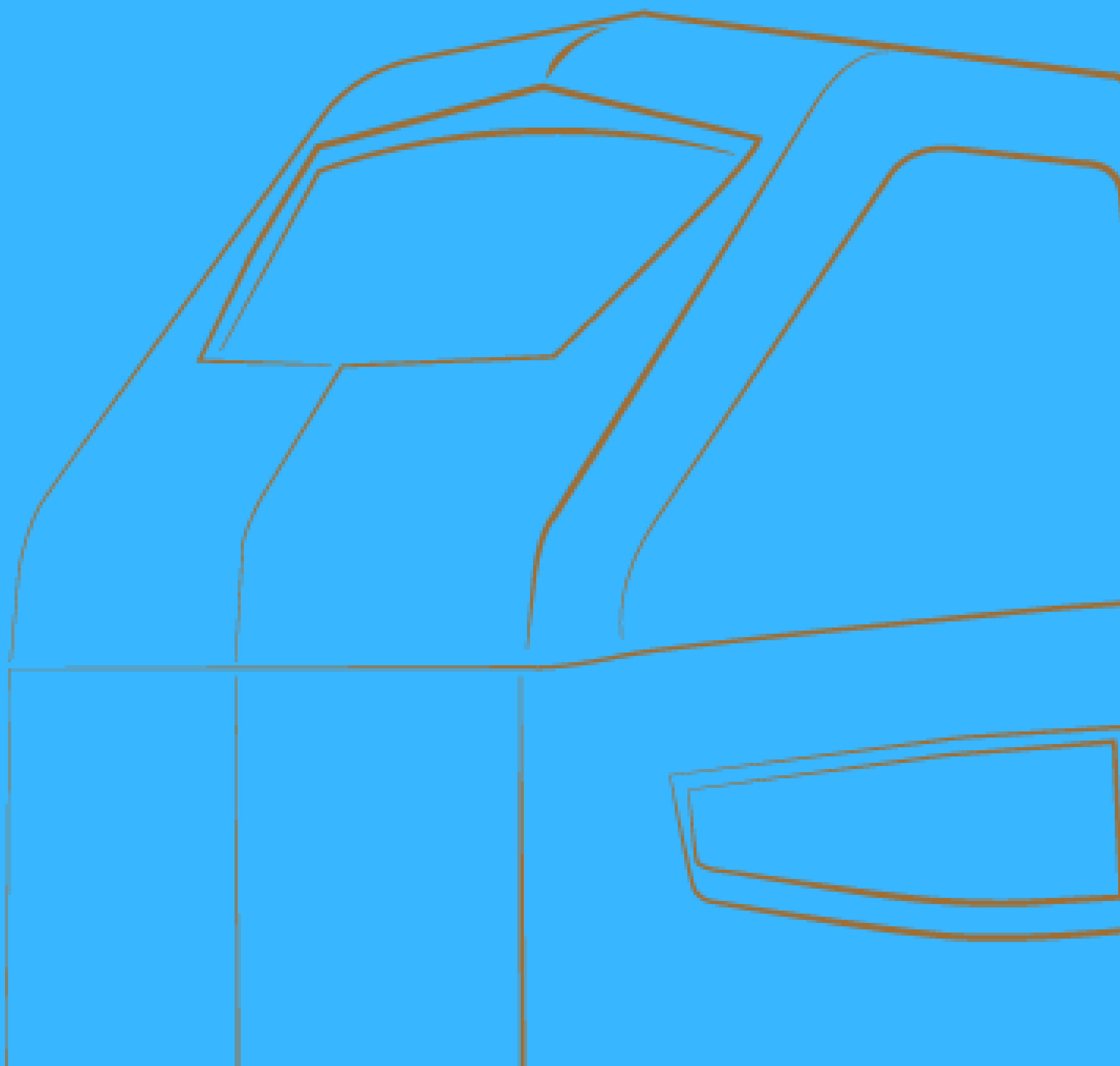

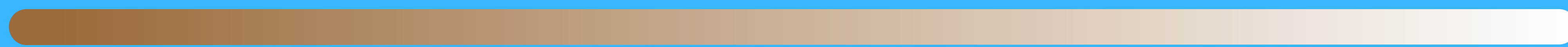
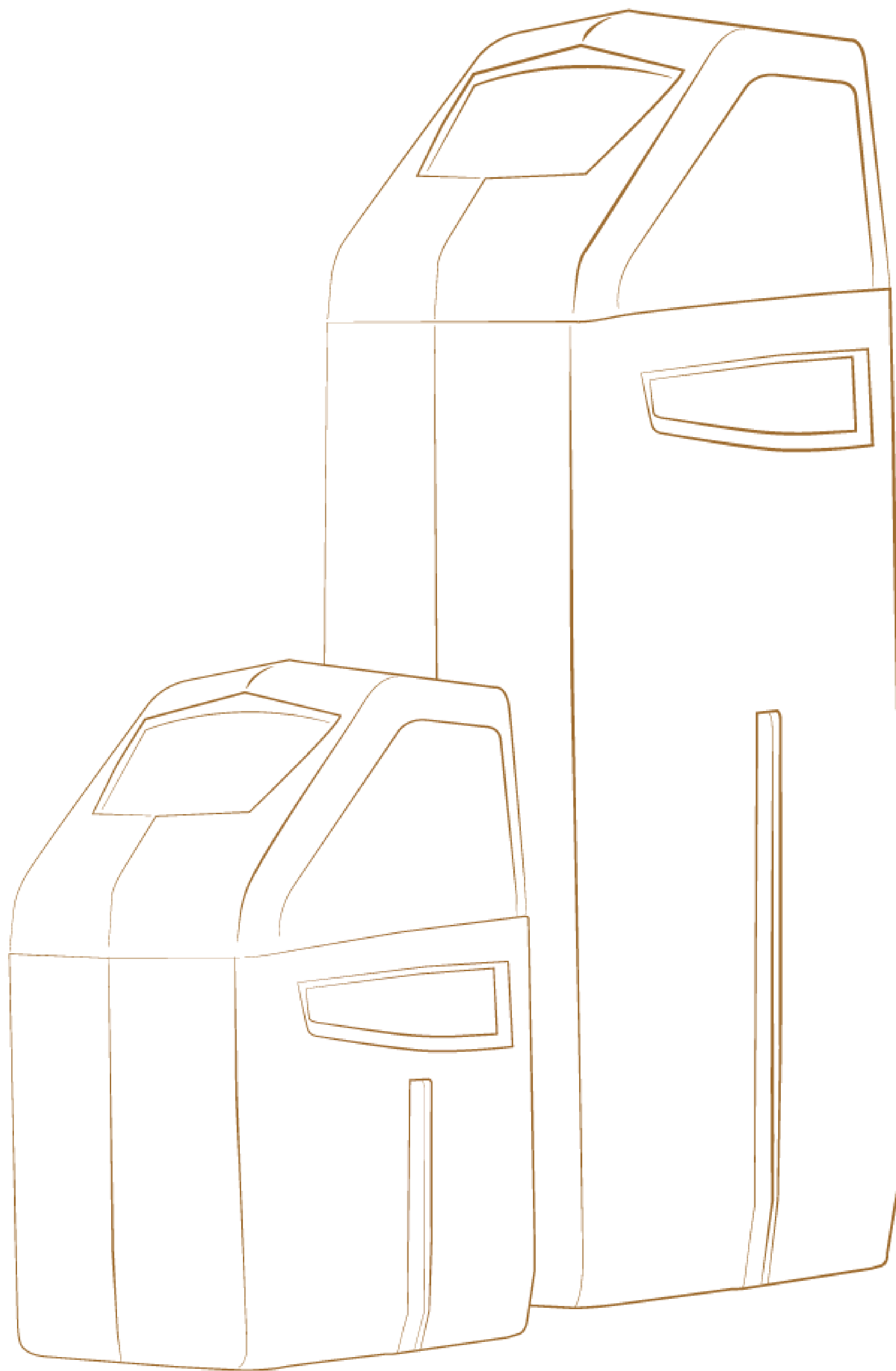

Filtrato Monoblock water softeners designed and produced entirely in Italy is a best product of design, versatility and functionality.

The linearity of the shapes and the chromatic variations make it a modern design object,

suitable to furnish different spaces while preserving functionality: a linear body with a

dedicated housing for the universal chlorine generators completed by a semi-

transparent front cover that can be removed without interfering with the valve.

## Two Versions

✓ **15Lt**

✓ **25Lt**



**ITALIAN PRODUCT**

*Entirely projected and made in Italy*



**INNOVATIVE DESIGN**

*Linear and elegant shapes*



**COMPLETENESS**

*Monoblock cabinet with salt well*

# Dimensions

## 15Lt

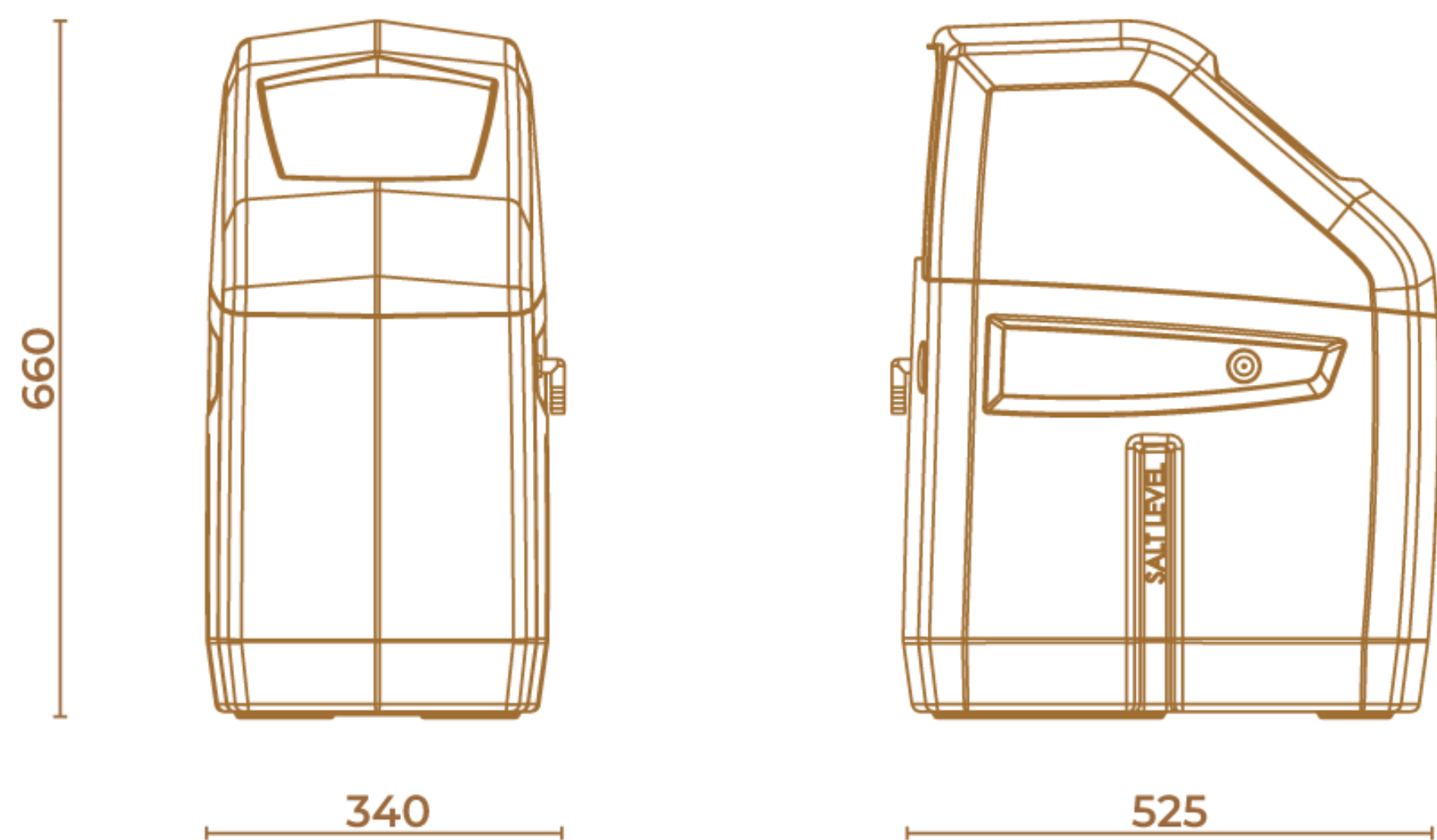

## 25Lt

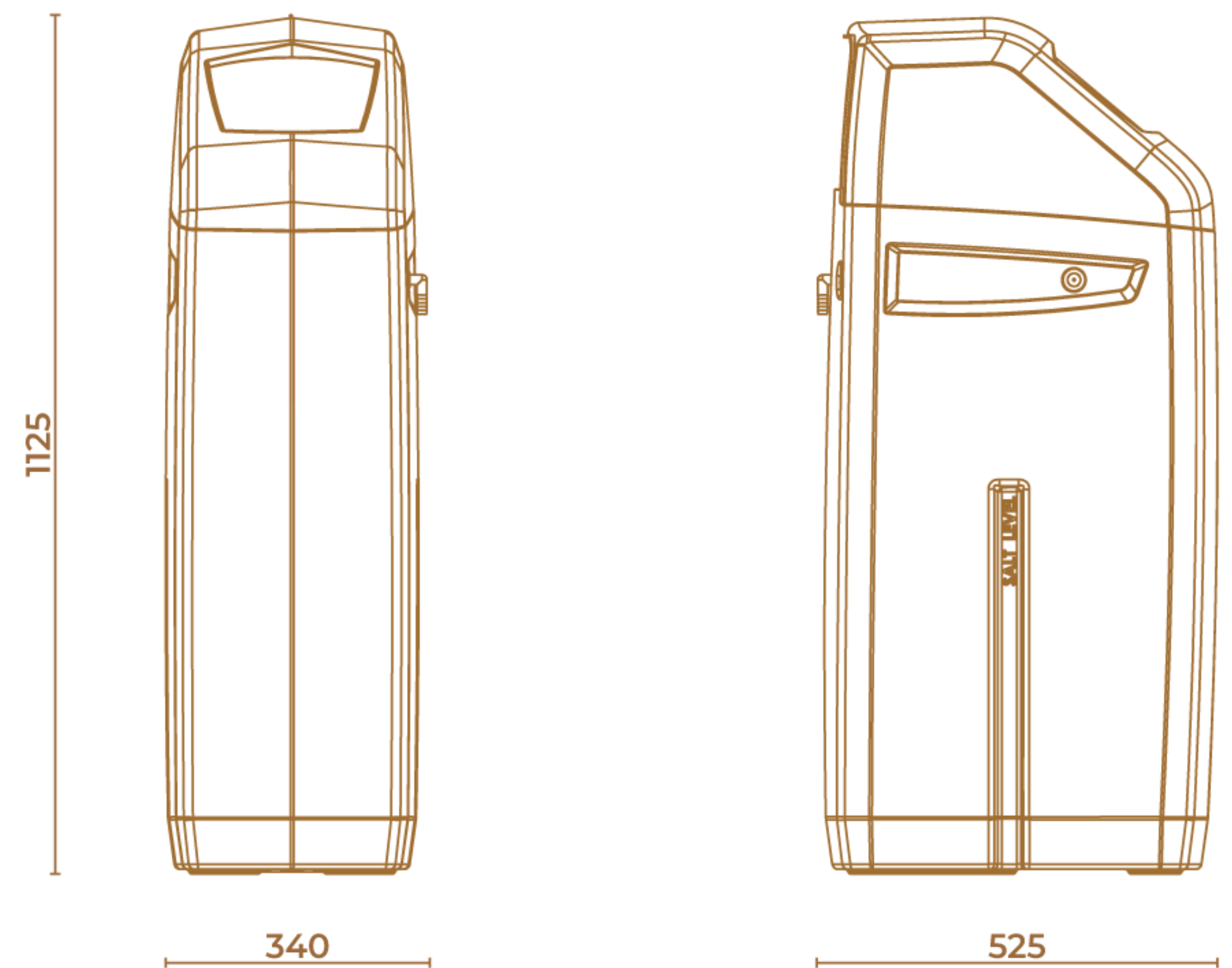

# Runxin Control Valve



## Advantages

- Electronic demand (volumetric)
- Calendar override
- 12V operation
- High efficiency regeneration sequence
- Automatic capacity calculations
- Made in China

